

Security is the foundation of everything we do at AWS

PEOPLE & PROCESS

SYSTEM

NETWORK

PHYSICAL

NASA, Shell, GE, Pfizer, Tokyo Stock Exchange, Bristol-Myers Squibb, NASDAQ, CDC

Requirements from toughest customers; audited and validated by experts

Every Customer Benefits

Familiar security model

Physical Security

Network Security

Platform Security

People & Procedures

Inherit global security and compliance controls

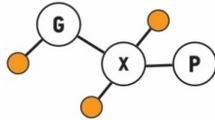

MapmyIndia Data Infrastructure

- 30mn+ Addresses
- 6.4mn+ Road Kms
- 400+ Categories of Places
- 70mn+ Places (with meta-data)
- 3k+ Search Keywords
- 100k+ Localities
- 100K+ Sub localities
- 7.6k+ Cities & Towns
- 750k+ Villages
- 6.9k+ Subdistricts

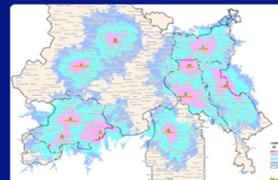
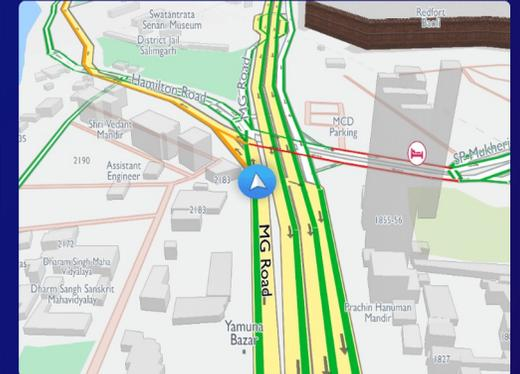
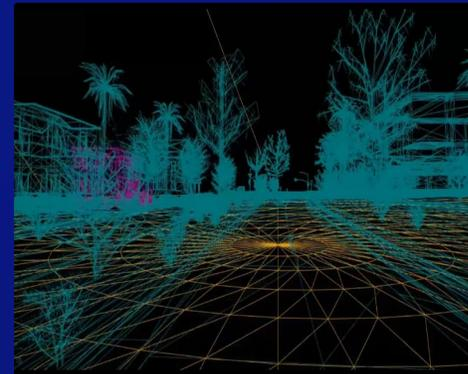
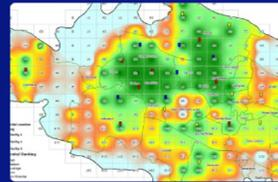
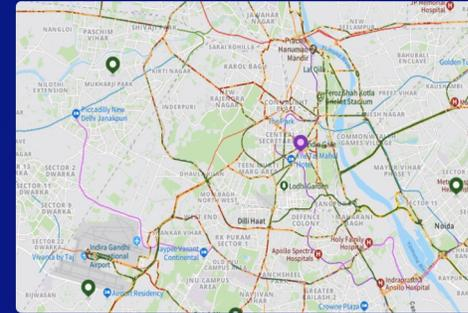

- Metaverse & HD Maps
- Boundary Data
- Micro-Affluence
- Micro-Demographics
- Rural Potential Index
- Quality of Life Data

- Annual Average Daily Traffic
- Drone Imagery & Layers
- Satellite Imagery
- Earth Observatory Data (ISRO)
- Real View Street Imagery
- 3D Building Data

Flipping the flow of data: Bring compute to the data

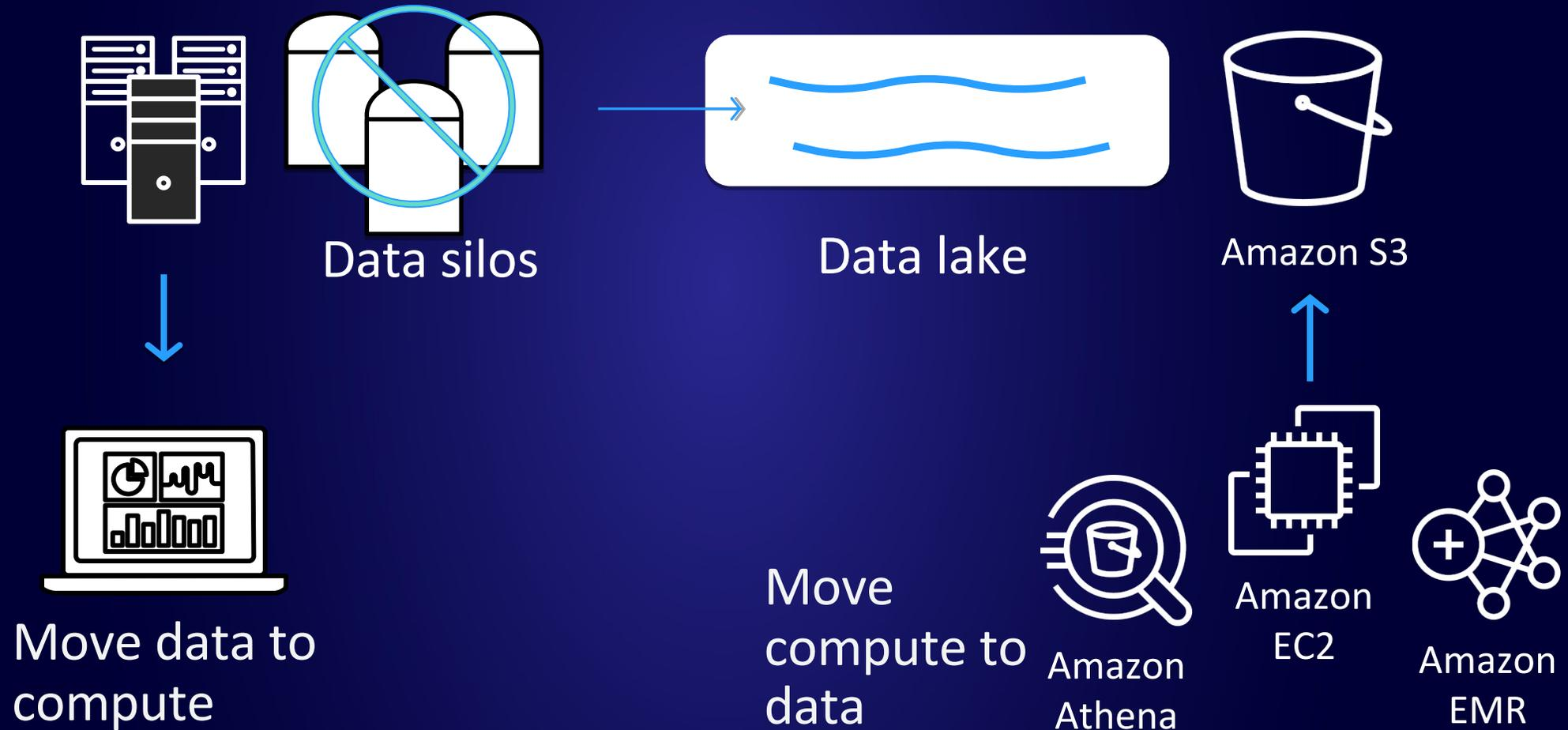

Sharing data in the cloud lets data users spend more time on data analysis rather than data acquisition

opendata.aws

Advantages of sharing data in the cloud



Global community of users



New services and tools



Faster pace of research



Lower cost of research

Finding and sharing open data on AWS

Monitoring at-risk bodies of water from space

- The **Blue Dot Observatory** uses Sentinel-2 satellite data on AWS to monitor water bodies around the world.
- “The cost to process one month of data for about 7,000 bodies of water currently in the system is 6 EUR. It is possible to set up world-scale systems with a shoestring budget.”

– *Anze Zupanc, Data scientist, Sinergise*

- opendata.aws/bluedot



MODIS

NOAA GHE

USGS 3DEP LiDAR

NWM

GEFS

TCGA

OpenStreetMap

GEOS-Chem

ECMWF ERA5

NEXRAD

Sentinel-1

HRRR

Sentinel-2

OFS

eBird

Terrain Tiles

GOES-16

NAIP

CBERS

NOAA ERI

HIRLAM

ISD

Registry of Open Data on AWS

gnomAD

GHCN

Kids First

Landsat

GFS

SILAM Air Quality

NREL Solar Radiation

CESM LENS

TARGET

GOES-17

OpenAQ

NREL Wind Integration

Common Crawl

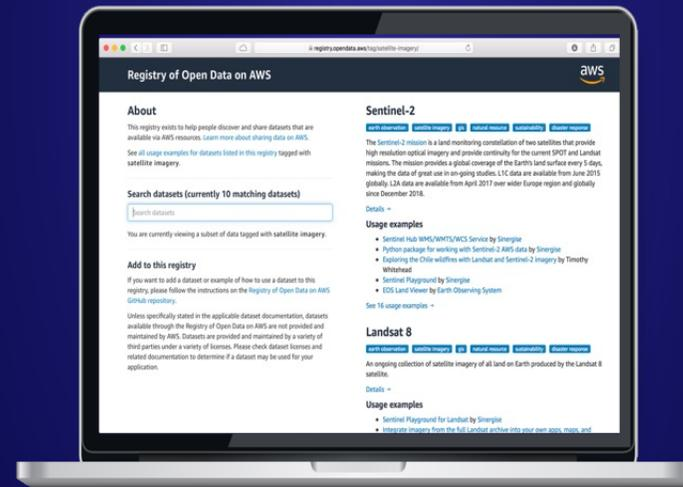

registry.opendata.aws

Critical infrastructure sectors are **evolving** on AWS

Critical Indian Government Workloads **running** on AWS



Cowin – India Covid Vaccination Platform

Powering the world's largest vaccination drive

Objective

To facilitate seamless appointment scheduling, verification, and certification for Covid-19 vaccination of 130+ crore Indians

Salient Features

- Provides **low latency** user access for healthcare practitioners
- Maintains consistent performance at a **national scale**
- Scales up and down **without interruption** to spikes in traffic
- Delivers **disaster recovery** capability
- **Minimizes** operational and support overhead



Network Controls: AWS cryptography stack



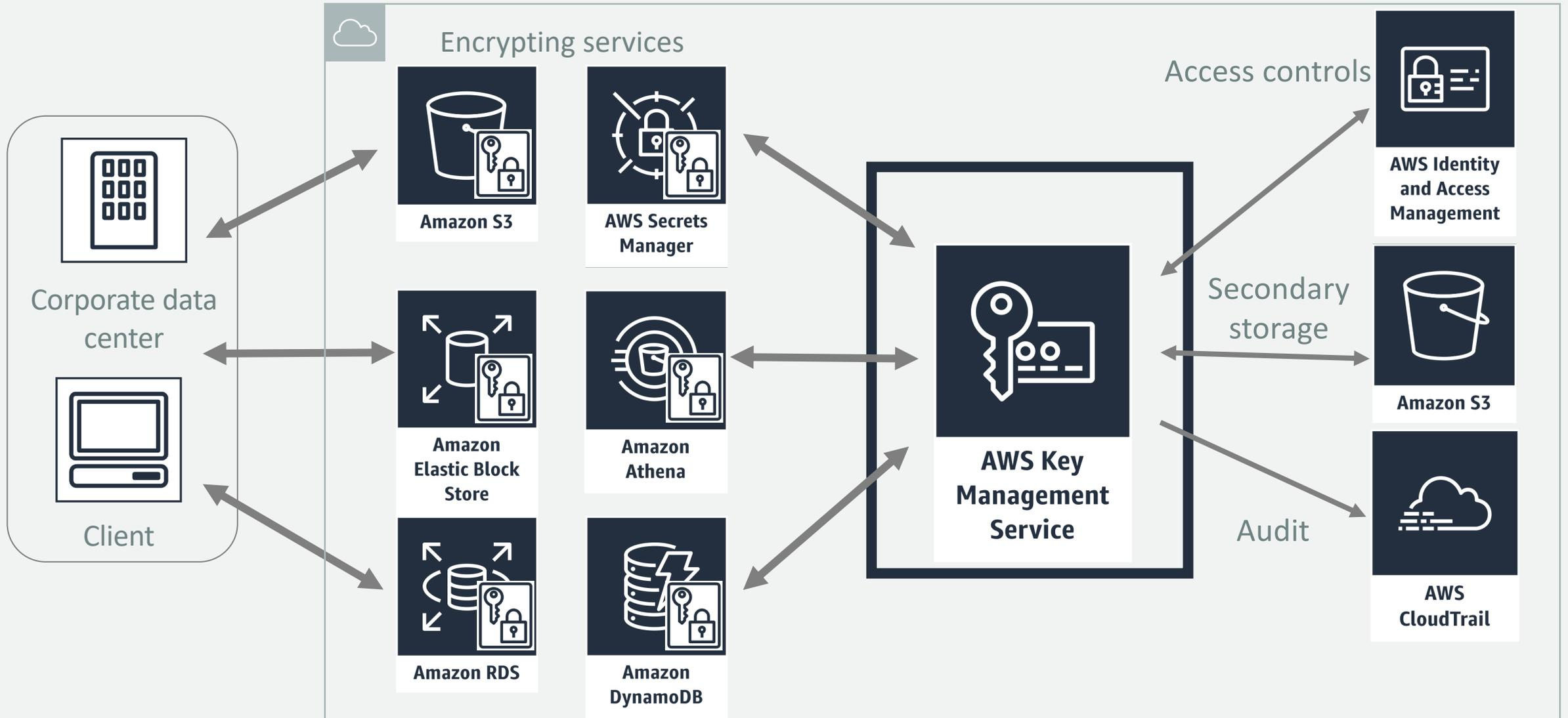

Interacting with AWS Application Programming Interfaces (APIs)

ZERO TRUST WITHIN AWS

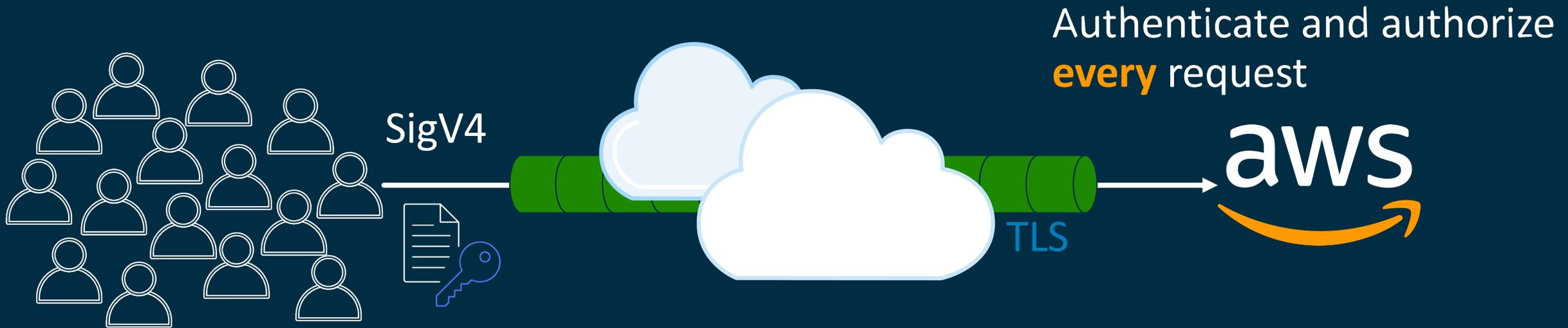

Use case 0 for Zero Trust?

Using ML to enable threat detection at scale

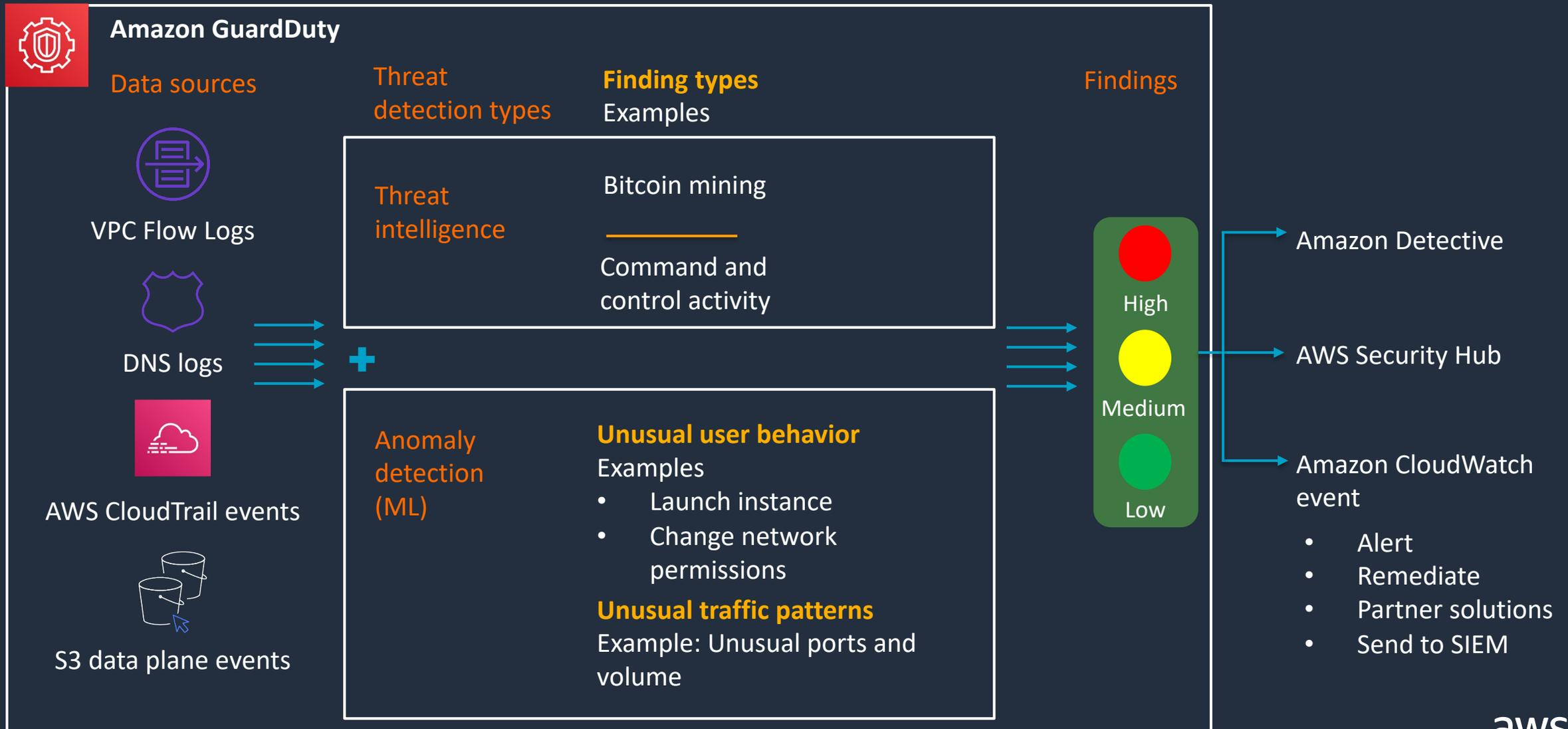

AWS foundational and layered security services



AWS Organizations



AWS Shield



AWS Certificate Manager



AWS KMS



AWS Network Firewall



Amazon GuardDuty



Amazon Macie



Amazon CloudWatch



AWS Step Functions



AWS OpsWorks



AWS Security Hub



AWS WAF



AWS Firewall Manager



AWS CloudHSM



AWS Secrets Manager



Amazon Inspector



AWS Security Hub



AWS Systems Manager



AWS Lambda



AWS CloudFormation

Identify



Protect



Detect



Respond



Recover



AWS Config



AWS Trusted Advisor



Amazon Cloud Directory



IAM



AWS Transit Gateway



Amazon VPC



AWS Systems Manager



AWS Control Tower



AWS Single Sign-On



AWS Directory Service



Amazon VPC PrivateLink



AWS Direct Connect



Amazon Cognito



Amazon Detective



Amazon CloudWatch



AWS CloudTrail



Amazon S3 Glacier



CloudEndure Disaster Recovery



Snapshot Archive



Thank You

Vikas Tiwari

 [vtiwari4](#)

tiwvika@amazon.com



AWS Nitro system

Nitro Cards

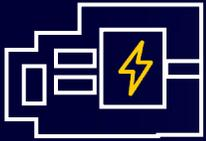

Nitro Card for VPC

Nitro Card for EBS

Nitro Card for Instance Storage

Nitro Card Controller

Nitro Security Chip

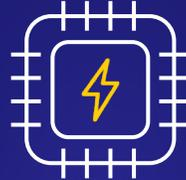

Integrated into motherboard

Protects hardware resources

Root of trust

Nitro Hypervisor

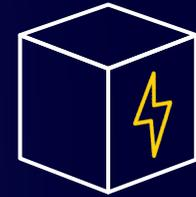

Lightweight hypervisor

Memory and CPU allocation

Bare metal-like performance

Modular building blocks for secure and rapid design and delivery of EC2 instances

Nitro controller and Nitro security chip

- Nitro Controller coordinates all other Nitro cards, the server hypervisor, and the Nitro Security Chip and implements HW root of trust
- Nitro security chip blocks all write-access to non-volatile storage and implements the hardware root of trust
- Locked down security model prohibits all administrative access

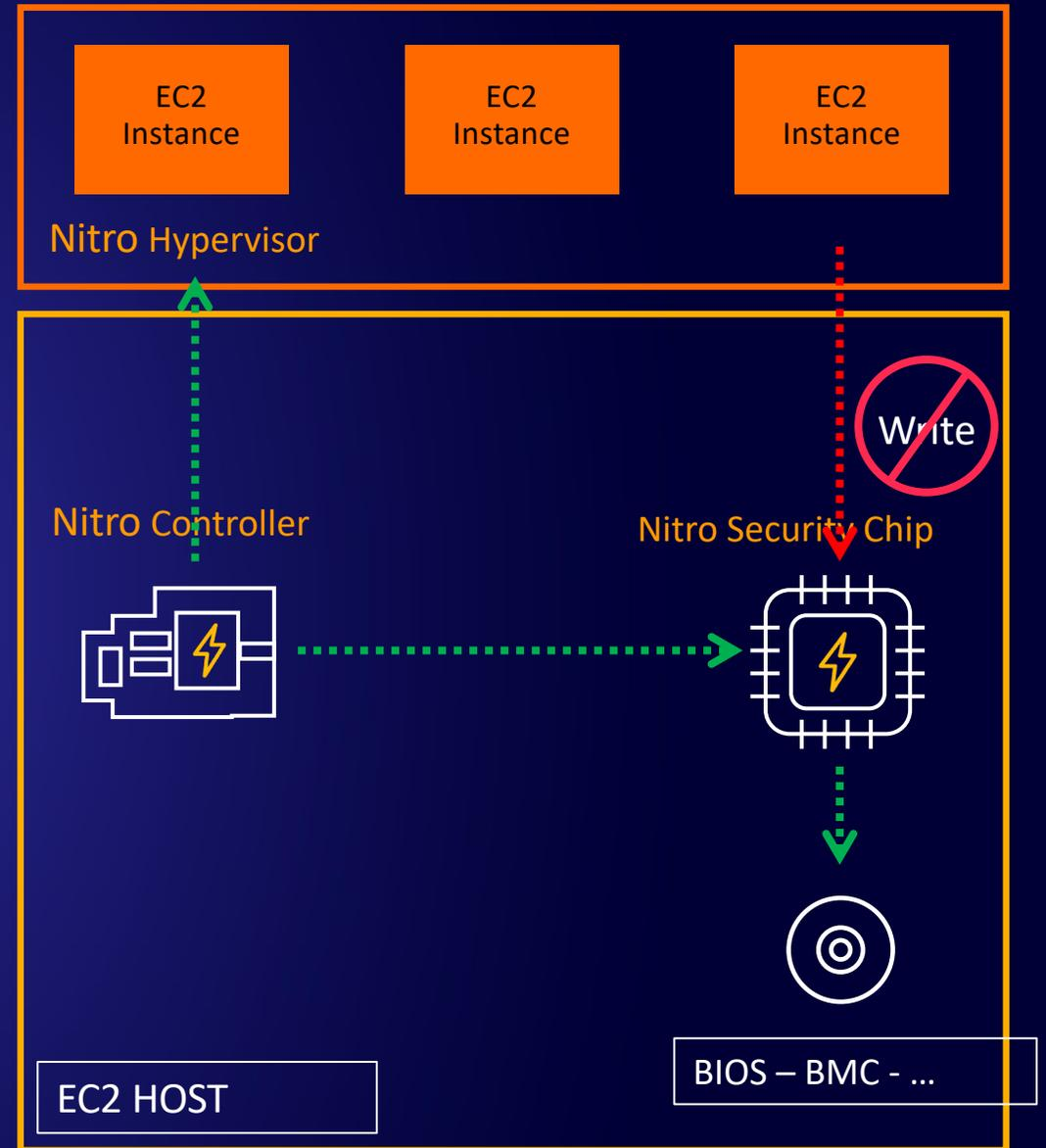

AWS Nitro Enclaves – Confidential Computing

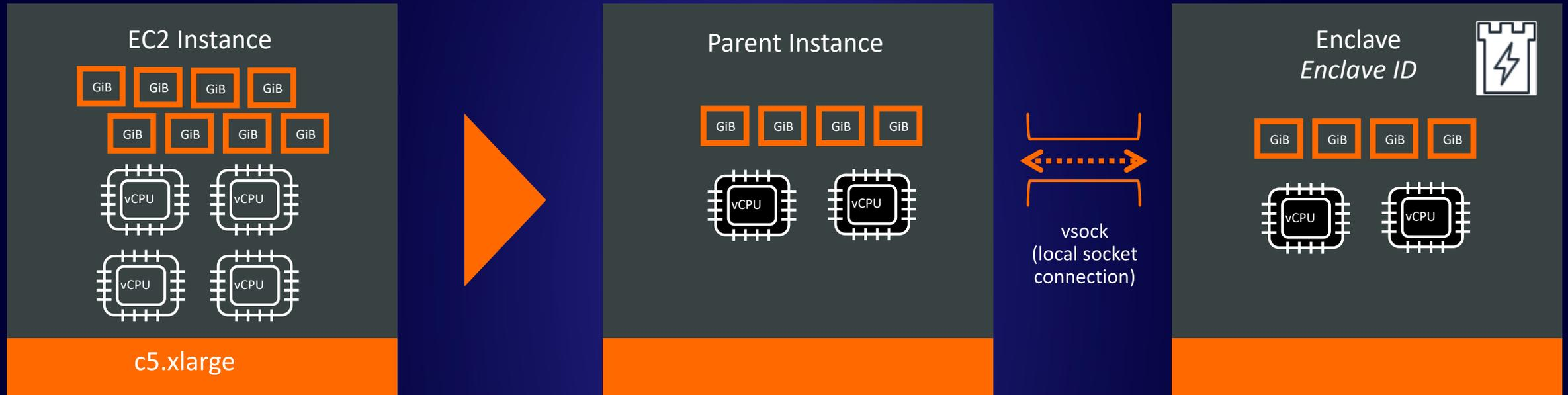

- Partition the CPU and Memory of EC2 instance
- Resources are allocated to the enclave for the duration of its lifetime
- Enclave is active only while its parent instance is in the running state
- Single Enclave per parent